

State of Iowa
DEPARTMENT OF EDUCATION
Career Education Division
Grimes State Office Building
Des Moines, IA 50319

CONTESTANT NAME _____

CONTESTANT SCHOOL _____

MACHINERY AND EQUIPMENT SYSTEMS
Problem Solving/Skill

Instructions:

You will have 15 minutes to do this exercise. Using the sections from the owner's manual, and your knowledge of balers, answer the following questions.

I. What are the last 3 digits of: 1 pt.

a) Product (Baler) Identification Number _____

II. Identify by proper name the machine components and their function. 8 pts.

Name	Function
a) _____	_____
b) _____	_____
c) _____	_____
d) _____	_____

III. What are the lubrication intervals for the following: 6 pts.

a) pick-up lift crank _____	d) wheel bearings _____
b) roller chains _____	e) PTO driveline _____
c) twine actuator rod _____	f) pick-up drive idler _____

IV. What SAE oil viscosity is used for the gear box? _____ gear box capacity? _____ qt 2 pts.

V. What's average estimated bale weight? _____ lb 7 pts.

What's the maximum bale diameter? _____ in.

How much does the empty baler weigh? _____ lb

What's the minimum recommended tractor power? _____ hp Minimum hydraulic flow? _____ gal/min

What's the recommended tire inflation pressure? _____ psi

How wide is a bale? _____ in.

Evaluation Score Sheet

<u>Items</u>	<u>Points</u>	
	<u>Possible</u>	<u>Earned</u>
PIN.....	1	_____
Part Identification/Function.....	8	_____
Lubrication intervals.....	6	_____
Gear box oil.....	2	_____
Bale, baler, and tractor specifications.....	7	_____
Safety.....	1	_____
Total	25	

Iowa FFA Agricultural Mechanics Career Development Event
2008

State of Iowa
DEPARTMENT OF EDUCATION
Career Education Division
Grimes State Office Building
Des Moines, IA 50319

CONTESTANT NAME _____

CONTESTANT SCHOOL _____

ENERGY SYSTEMS
Problem Solving/Skills
Motor Controls, Remote Sensors

Connecting a Motor to a Branch Circuit Cable
(15 minutes)

All materials needed are at the work stations. First, draw the wiring circuit below using a _____ solid line for the black wire, ----- dashed for the neutral (white) wire and dots for the safety ground. Second, connect the circuit. Refer to the connection instructions on the motor. Third, complete the specifications. Connect a motor to a 120-V branch circuit cable, and safety ground the motor. Use the cable clamp. Do not install the cover plate.

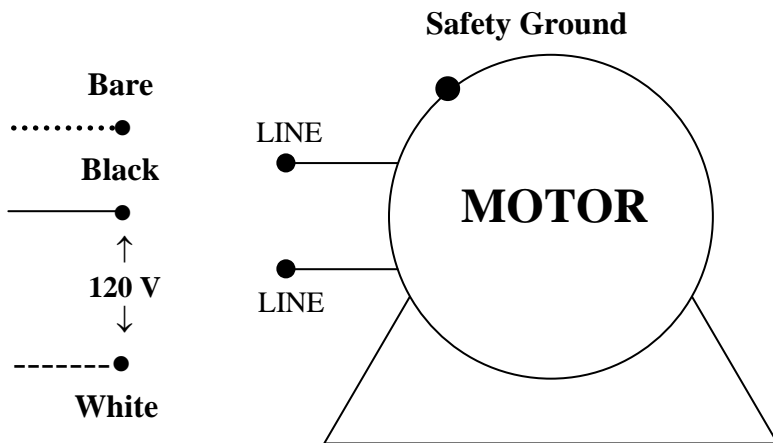

Specifications Section

- As connected, and when viewed from the connections end, this motor will turn (circle): clockwise, counterclockwise, can't tell
- Full load amps of motor on 120 volts _____ amps

After completing the exercise on paper, complete the actual connection of the motor using the materials provided at the work station. When completed, place your work station in order and request the judge to come to your station to evaluate your completed exercise.

Evaluation Score Sheet

<u>Items</u>	<u>Points</u>	
	<u>Possible</u>	<u>Earned</u>
1. Wiring Diagram	5	_____
2. Specifications and questions (3 points each)	6	_____
3. Connecting the motor		
a) Motor properly connected.....	8	_____
b) Wiring color code followed.....	3	_____
c) Cable clamp used correctl		1 _____
4. Safety and work habits.....	2	_____
Total	25	_____

Iowa FFA Agricultural Mechanics Career Development Event
2008

State of Iowa
DEPARTMENT OF EDUCATION
Career Education Division
Grimes State Office Building
Des Moines, IA 50319

CONTESTANT NAME _____

CONTESTANT SCHOOL _____

Structural Systems
Wood Construction Stud Frame Wall

You will have **15 minutes** to complete this activity. Your job is to layout and nail two short studs on to a bottom plate of a stud-frame wall. Study the plan of the completed job. Measure and cut the two studs from the 2x4 furnished. Layout and mark the end stud and first stud 16" on-center on the plate. Toe-nail the two studs to the plate assuming the plate is in place, nailed solid to a sub-floor.

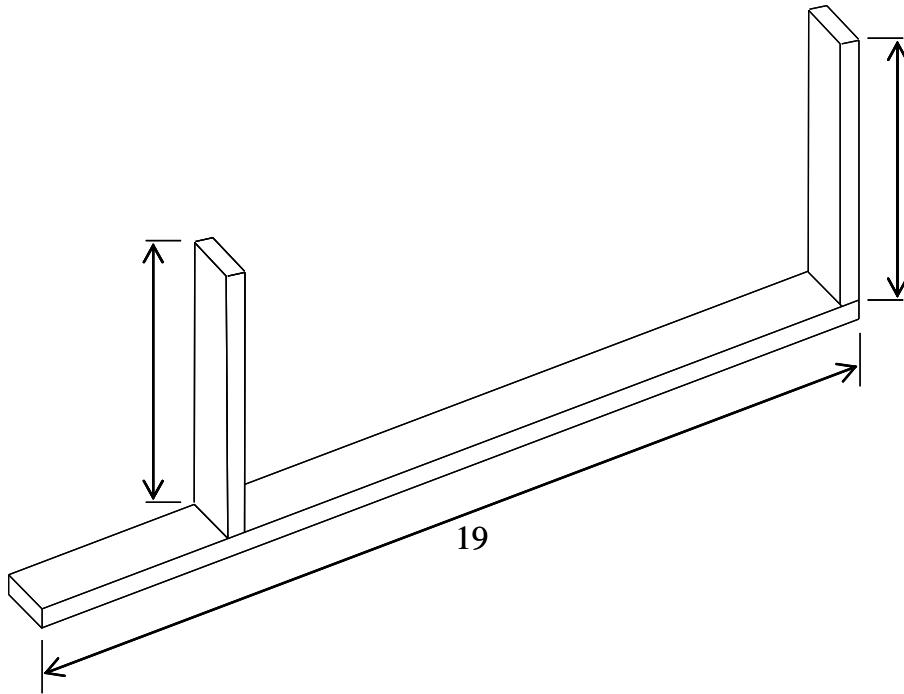

Use the tools, materials, and sawhorse at your work station to complete this job. When completed turn in your skill sheet for evaluation and leave your work station in order.

Evaluation Score Sheet

<u>Items</u>	<u>Points</u>	
	<u>Possible</u>	<u>Earned</u>
1. Length of studs.....	4	_____
2. Length of plate	4	_____
3. Layout of studs on plate, 16" O.C.....	5	_____
4. Location of studs on plate	5	_____
5. Correct number of nails and proper nailing of studs to plate	5	_____
6. Use of tools, safety and work habits	2	_____
Total	25	

Iowa FFA Agricultural Mechanics Career Development Event
2008

State of Iowa
DEPARTMENT OF EDUCATION
Career Education Division
Grimes State Office Building
Des Moines, IA 50319

CONTESTANT NAME _____

CONTESTANT SCHOOL _____

INDUSTRY AND MARKETING SYSTEMS

Problem Solving/Skill
Selecting a hydraulic cylinder
15 minutes

Problem Statement: A hydraulic cylinder is used to increase the density of biomass before entering a processing plant. The original material is placed in a round container with a cross sectional area of 4 ft². The container is filled to a width of 6 ft. The hydraulic cylinder will need to apply a force of 6,000 lbs in order to press the biomass material to a final width of 2 ft. The pump can supply a maximum hydraulic pressure of 1000 lbs/in² and a flow rate of 3 gal/min. There are 231 in³ in a single gallon. See figure of hydraulic cylinder on the following page.

I. What size (diameter and length) hydraulic cylinder should be chosen?

II. What is the correct cylinder part number from the table?

III. How much oil is needed to fully extend the cylinder?

IV. How long will it take the cylinder to extend and compress the biomass?

Evaluation Score Sheet

<u>Items</u>	<u>Points</u>	
	<u>Possible</u>	<u>Earned</u>
1. Cylinder Length	2	_____
2. Cylinder Diameter	6	_____
3. Cylinder Part Number	5	_____
4. Oil Volume.....	6	_____
5. Cylinder Extension Speed.....	6	_____
Total	25	<div style="border: 1px solid black; width: 60px; height: 40px; display: inline-block;"></div>

Iowa FFA Agricultural Mechanics Career Development Event
2008

State of Iowa
DEPARTMENT OF EDUCATION
Career Education Division
Grimes State Office Building
Des Moines, IA 50319

CONTESTANT NAME _____

CONTESTANT SCHOOL _____

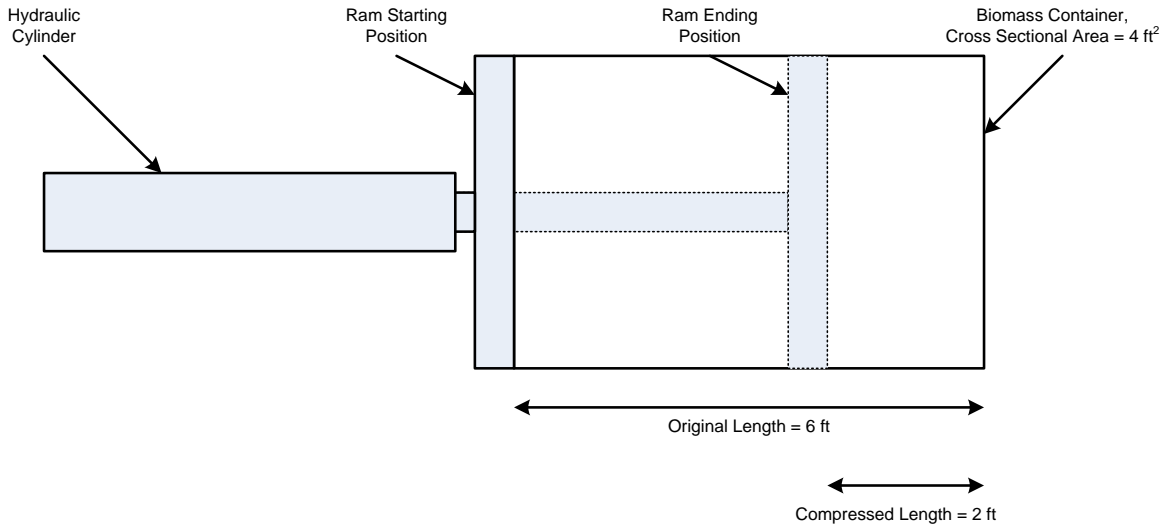

Hydraulic Cylinder Part Number Table									
		Hydraulic Cylinder Length (inches)							
		12	24	36	48	60	72	84	96
Hydraulic Cylinder Diameter (inches)	0.25	HL12D0.25	HL24D0.25	HL36D0.25	HL48D0.25	HL60D0.25	HL72D0.25	HL84D0.25	HL96D0.25
	0.5	HL12D0.5	HL24D0.5	HL36D0.5	HL48D0.5	HL60D0.5	HL72D0.5	HL84D0.5	HL96D0.5
	0.75	HL12D0.75	HL24D0.75	HL36D0.75	HL48D0.75	HL60D0.75	HL72D0.75	HL84D0.75	HL96D0.75
	1	HL12D1	HL24D1	HL36D1	HL48D1	HL60D1	HL72D1	HL84D1	HL96D1
	1.5	HL12D1.5	HL24D1.5	HL36D1.5	HL48D1.5	HL60D1.5	HL72D1.5	HL84D1.5	HL96D1.5
	2	HL12D2	HL24D2	HL36D2	HL48D2	HL60D2	HL72D2	HL84D2	HL96D2
	2.5	HL12D2.5	HL24D2.5	HL36D2.5	HL48D2.5	HL60D2.5	HL72D2.5	HL84D2.5	HL96D2.5
	3	HL12D3	HL24D3	HL36D3	HL48D3	HL60D3	HL72D3	HL84D3	HL96D3
	3.5	HL12D3.5	HL24D3.5	HL36D3.5	HL48D3.5	HL60D3.5	HL72D3.5	HL84D3.5	HL96D3.5
	4	HL12D4	HL24D4	HL36D4	HL48D4	HL60D4	HL72D4	HL84D4	HL96D4
	5	HL12D5	HL24D5	HL36D5	HL48D5	HL60D5	HL72D5	HL84D5	HL96D5
6	HL12D6	HL24D6	HL36D6	HL48D6	HL60D6	HL72D6	HL84D6	HL96D6	
8	HL12D8	HL24D8	HL36D8	HL48D8	HL60D8	HL72D8	HL84D8	HL96D8	

Iowa FFA Agricultural Mechanics Career Development Event
2008

State of Iowa DEPARTMENT OF EDUCATION
Career Education Division
Grimes State Office Building
Des Moines, IA 50319

CONTESTENT NAME _____

CONTESTANT SCHOOL _____

ENVIRONMENTAL & NATURAL RESOURCE SYSTEMS

Problem Solving/Skills
(15 minutes)

INSTRUCTIONS: Determine the elevations at each of the stations specified below. An automatic level was used to read a back-sight (B.S.) and a foresight (F.S.) from the adjacent turning points (T.P.). Start at the top of the survey table and calculate the Height of the Instrument (H.I.) for each automatic level setup and the elevation at each of the three turning points (T.P.) and the bench mark (B.M.).

Differential Leveling: Davidson Hall ISU				
Station	B.S. (+ sight)	H.I.	F.S. (- sight)	Elevation
B.M.	5.68			100.00
T.P.1	4.32		4.39	
T.P.2	3.98		4.02	
T.P.3	6.01		5.89	
B.M.			5.82	
Sum Columns	B.S. Sum Total =		F.S. Sum Total =	

CALCULATE:

[Ending B.M. Elevation] [Beginning B.M. Elevation] = _____

[B.S. Sum Total] [F.S. Sum Total] = _____

Note: The difference between [Beginning B.M.1 elevation] and [Final B.M.1 elevation] should equal the difference between the [B.S. Sum Total] and the [F.S. Sum Total].

Give one possible source of error that might have occurred during the differential leveling exercise that may have caused the difference between the beginning and final B.M. elevation.

Answer: _____

EVALUATION SCORE SHEET

ITEM	POINTS		ITEM	POINTS	
	POSSIBLE	EARNED		POSSIBLE	EARNED
B.M. B.S.	2		T.P.1 F.S.	2	
T.P.1 B.S.	2		T.P.2 F.S.	2	
T.P.2 B.S.	2		T.P.3 F.S.	2	
T.P.3 B.S.	2		B.M. F.S.	2	
B.S. Total	2		F.S. Total	2	
Change in Elevation	2		B.S. Sum F.S. Sum	2	
Possible Error	1		TOTAL POSSIBLE	25	

State of Iowa
 DEPARTMENT OF EDUCATION
 Career Education Division
 Grimes State Office Building
 Des Moines, IA 50319

CONTESTANT NAME _____

CONTESTANT SCHOOL _____

COMPUTER APPLICATION
 (15 minutes)
NO CALCULATORS ARE PERMITTED.

A corn ethanol plant for which you work is considering an expansion. These additional grain conveyors will be installed as part of the expansion:

- Auger #1: 14 diameter, 260 rpm, horizontal (0° angle), 50 ft in length
- Auger #2: diameter 300 rpm, horizontal (0° angle), 30 ft in length
- Auger #3: diameter 260 rpm, 35° angle, 35 ft in length
- Bucket elevator: ft tall x bucket size bucket spacing belt speed of 565 ft/min

System Characteristics:

- An additional 1 million bushels of dry corn will be moved in a month.
- Electricity costs \$0.07 per kWh.
- 1 hp of conveyor power is equivalent to 1 kW of electricity.

You have been assigned the task of determining the energy requirements for moving the additional grain. Use the given Excel spreadsheet and data tables (on the back of this paper) to assist in predicting the energy required for each conveyor, the total amount of energy to operate all the conveyors, and the cost of that energy over a one-month period.

Follow this procedure:

1. Enter your name and school into the spreadsheet.
2. Enter the cost of electricity (\$/kWh) under system characteristics
3. Enter information for each conveyor in the light blue cells as appropriate.
4. In the green cells, enter a formula with cell references to calculate the required values.
5. Print out the completed spreadsheet.
6. **QUESTION.** Using the spreadsheet, answer the following question. If the cost of electricity were changed to \$0.10 per kWh, what would be the cost of energy for conveying grain over a one-month period? Write the answer below.

ANSWER: _____

7. Hand in this page and the printout to the judge.

Evaluation Score Sheet

<u>Items</u>	<u>Points</u>	
	<u>Possible</u>	<u>Earned</u>
1. Data entered correctly	8	_____
2. Values correctly calculated	8	_____
3. Printout.....	4	_____
4. Question answered	5	_____
Total	25	<div style="border: 1px solid black; width: 60px; height: 40px; margin: 0 auto;"></div>

Table 2-3. Estimated auger capacity and power.

For dry (14% maximum moisture content) corn. Values for 4" and 6" augers are based on a lot of data. Values for 8" and 10" augers are based on very limited data. Values for 12"-16" augers were extrapolated. Actual auger performance may vary so use manufacturer's data for designing auger systems. Multiply dry corn values by 0.6 for wet corn capacity. Use the table values for wheat, grain sorghum, oats, barley, and rye because actual values are only slightly less. For soybeans, multiply capacity by 0.75 and power by 1.10. Multiply bu/hr by 50 for approximate lb/hr capacity for meal or concentrate feed.

Auger dia., in.	Auger speed ¹ rpm	Incline angle									
		0°		25°		35°		45°		90°	
		bu/hr	hp/10'	bu/hr	hp/10'	bu/hr	hp/10'	bu/hr	hp/10'	bu/hr	hp/10'
4	900 ²	560	0.6	500	0.9	480	0.9	450	1.0	270	0.8
6	600	1,500	1.0	1,350	1.5	1,290	1.6	1,190	1.6	710	1.3
8	450	2,210	1.4	1,990	2.2	1,890	2.2	1,760	2.3	1,050	1.8
10	360	3,300	2.0	2,970	3.1	2,830	3.2	2,620	3.2	1,570	2.5
12	300	4,520	2.5	4,070	3.9	3,870	4.0	3,590	4.0	2,150	3.2
14	260	6,230	3.4	5,610	5.3	5,340	5.4	4,950	5.5	2,960	4.3
16	225	8,040	4.4	7,240	6.8	6,870	7.0	6,390	7.1	3,820	5.6

¹Auger speeds for 3,600 in/min flighting velocity along auger length (theoretical grain velocity) for all diameters.

²4" auger at 900 rpm vibrates excessively. 900 rpm values are for converting with Tables 2-4 and 2-5.

Table 2-8. Typical bucket elevator capacity and power.

Bucket size in.	Bucket spacing in.	Belt speed ft/min	Capacity bu/hr	Power requirements hp/10' height
4x3	8	240	200	0.10
	6	270	300	0.125
6x4	4¼	270	550	0.20
	4¼	335	700	0.25
7x5	8	335	900	0.30
	6	335	1,200	0.33
9x5	7	265	1,600	0.5
	6	300	1,800	0.5
9x6	12	385	1,500	0.625
	6	385	3,000	1.25
12x7	10	565	5,000	2
15x7	9	565	7,500	3
14x8	10	650	10,000	4