

State of Iowa
 DEPARTMENT OF EDUCATION
 Career Education Division
 Grimes State Office Building
 Des Moines, IA 50319

CONESTENT NAME _____

CONTESTANT SCHOOL _____

STRUCTURAL SYSTEMS

Arc Welding
 (15 minutes)

You have six (6) minutes to complete a fillet weld according to the drawing and eight (8) minutes to complete the quiz. Completely read the procedures below before beginning.

Procedures

1. Pick up two (2) pieces of pre-cut metal and one (1) E6013 electrode.
2. Select an arc welding machine. Make adjustments to the machine as you feel are necessary based on the electrode and the type of metal you are welding.
3. Follow safe welding procedures, including use of a welding mask, eye protection, gloves, and proper clothing. Be aware of the safety of others.
4. Complete the weld. Turn off the machine.
5. Clean the weld with a wire brush and chipping hammer. Cool the weld. Mark your weld with your name and school.
6. Complete the quiz.
7. Submit weld and this sheet to the judge for evaluation.

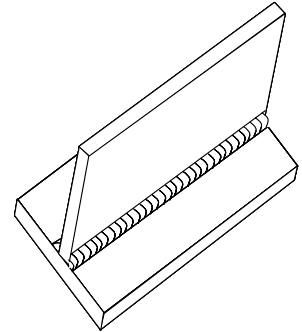

90° angle.
 Weld both sides.
 Vertical piece centered on horizontal piece.

Arc Welding Quiz

1. "Arc blow" is caused by an unbalanced condition in the electric field surrounding the arc.
2. A weld of approximately triangular cross-section joining two surfaces approximately at a right angle to each other is called a fillet weld.
3. A weld made in the groove between two members to be joined is called a groove weld.
4. A weld with poor penetration, slow progress, and excessive piling of weld metal is caused by _____.
5. A type of weld composed of one or more stringer or weave beads deposited on an unbroken surface is called a surfacing weld.

Evaluation Score Sheet

<u>Items</u>	<u>Points</u>	
	<u>Possible</u>	<u>Earned</u>
1. Correct welding procedures	5	_____
2. Correct assembly	5	_____
3. Quality of weld.....	7	_____
4. Safety and work habits	3	_____
5. Quiz	5	_____
Total	25	